

REV	ECN	DESCRIPTION	DATE	APPROVED
A	F170024	RELEASE	4/17/2017	DCCLARK
B	F170088	ADD SHEET 3: E324 24" STAND SURGE HPR FACTORY	7/28/2017	dmjohnson

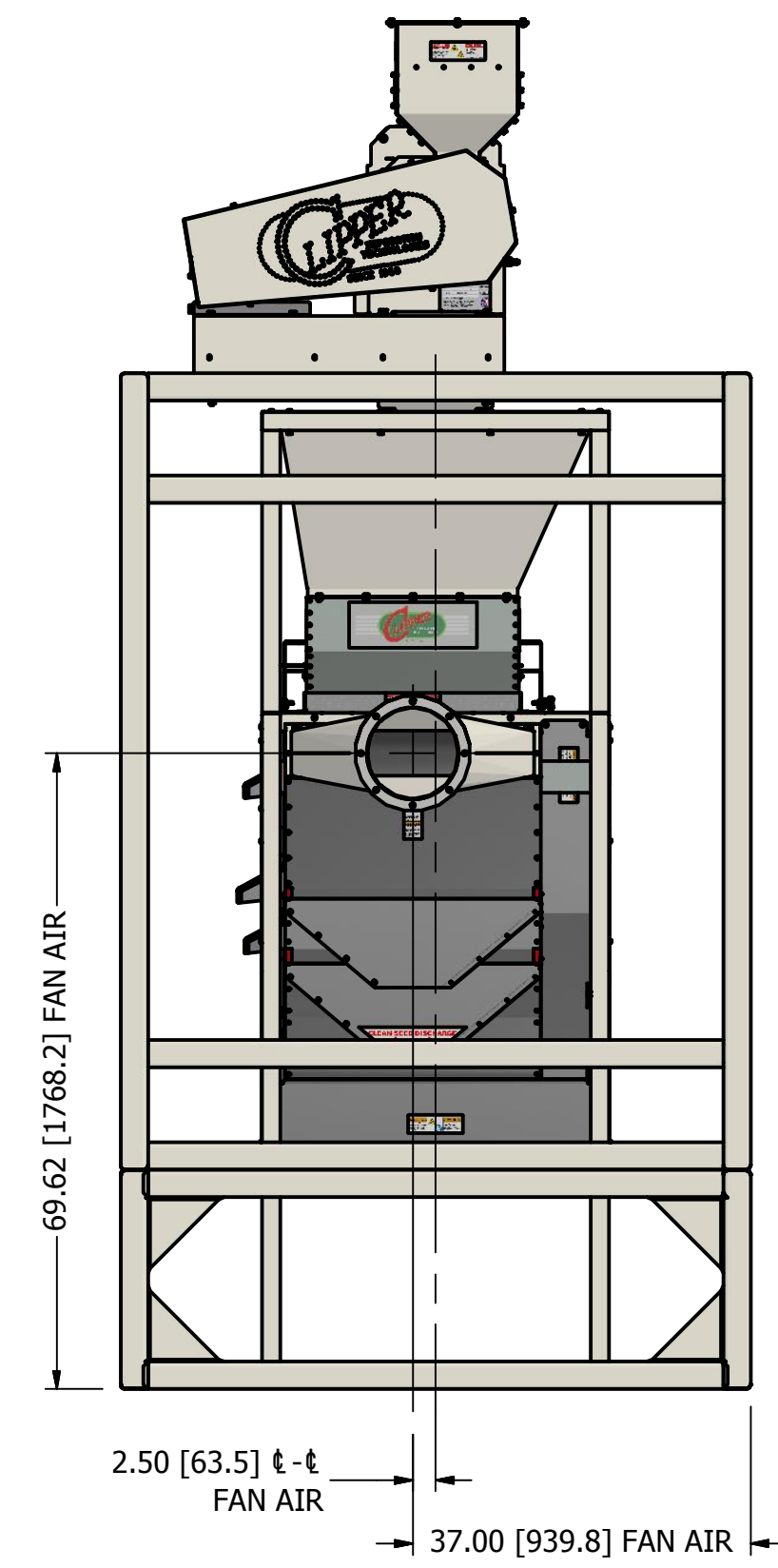

FRONT VIEW; DEBEARDER MINI, ECLIPSE 324, DEBEARDER SURGE HOPPER, ECLIPSE 324 5 BUSHEL SURGE HOPPER, FAN AIR TRANSITION & 24" STAND FACTORY

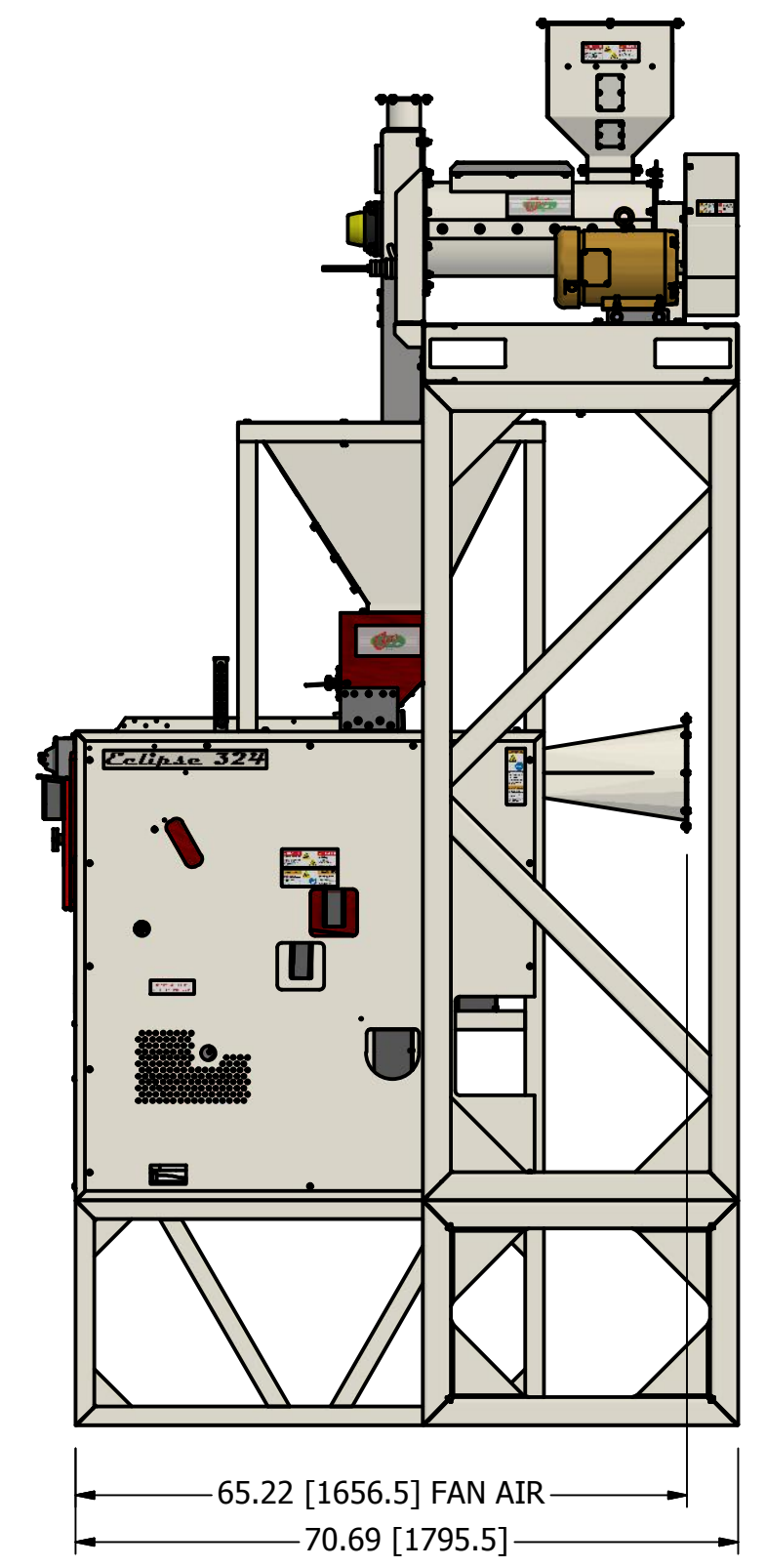
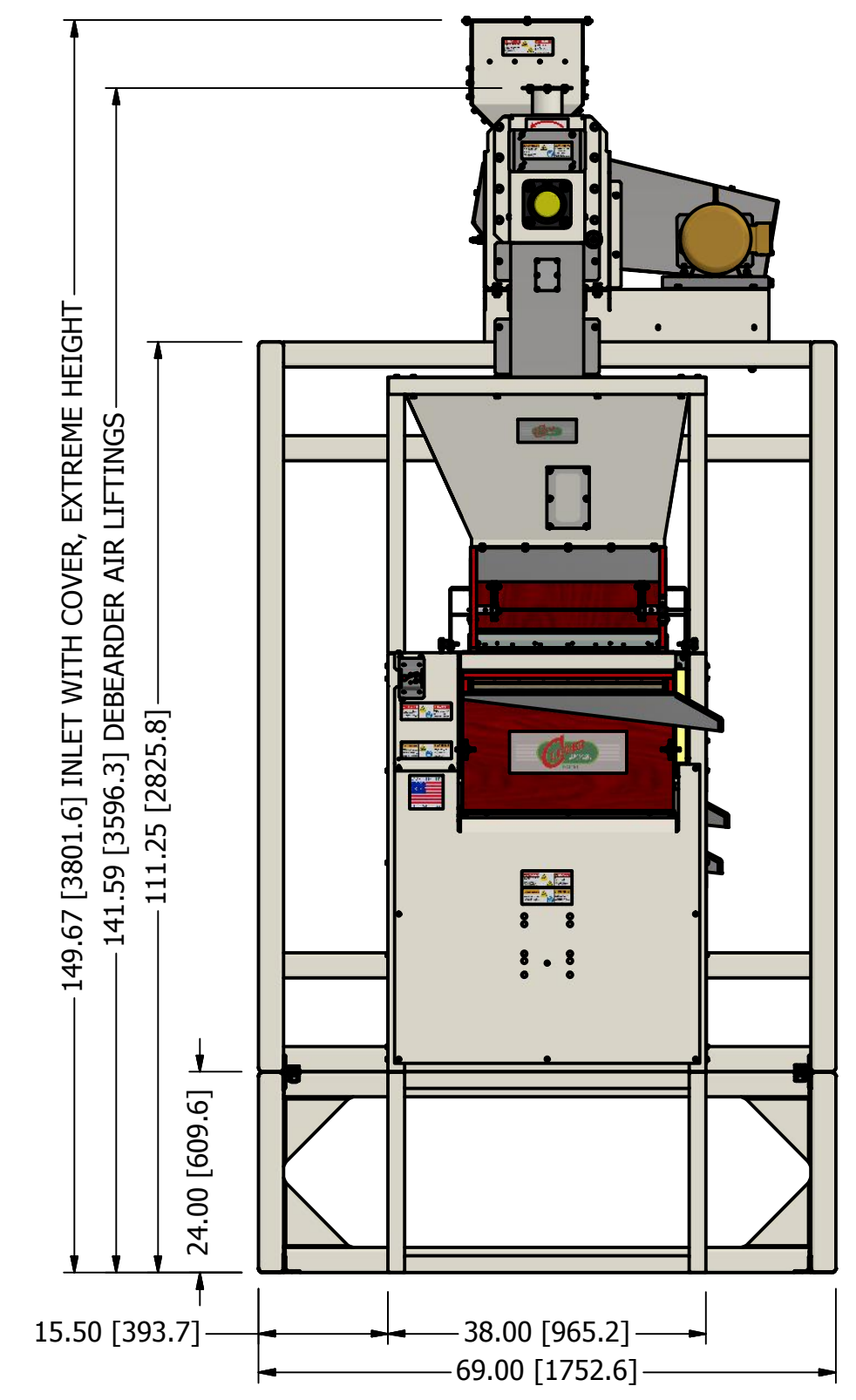
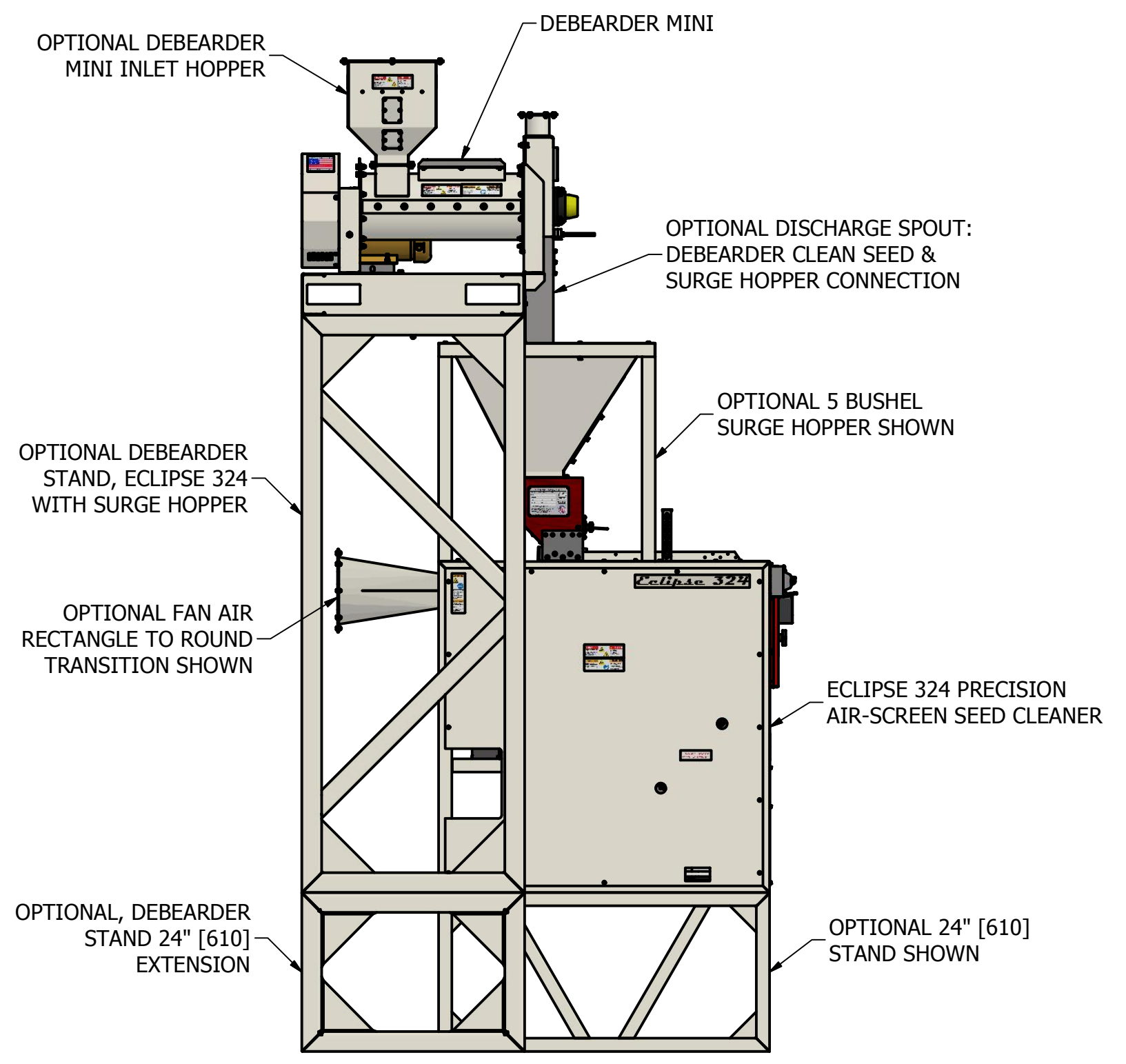
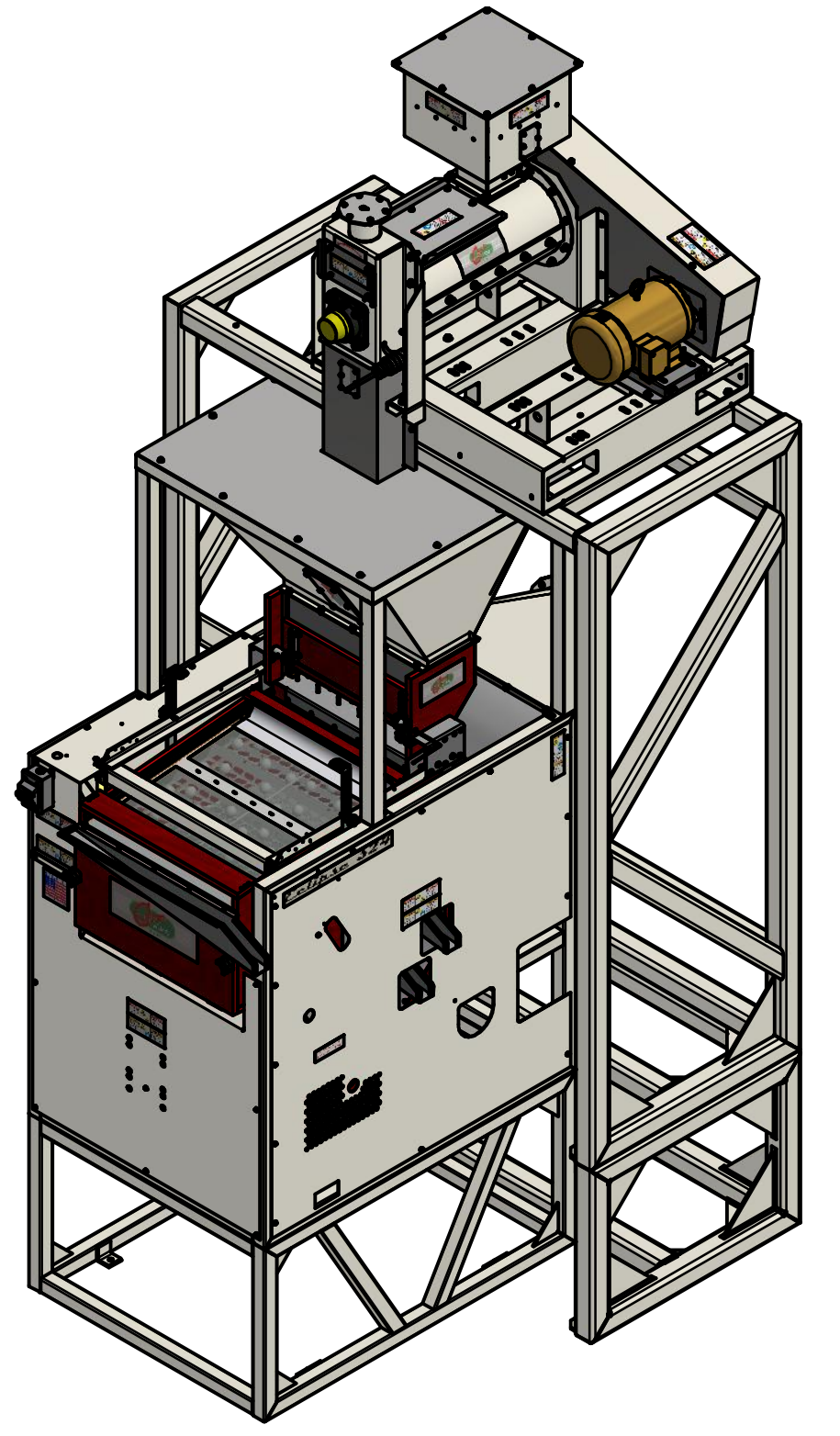
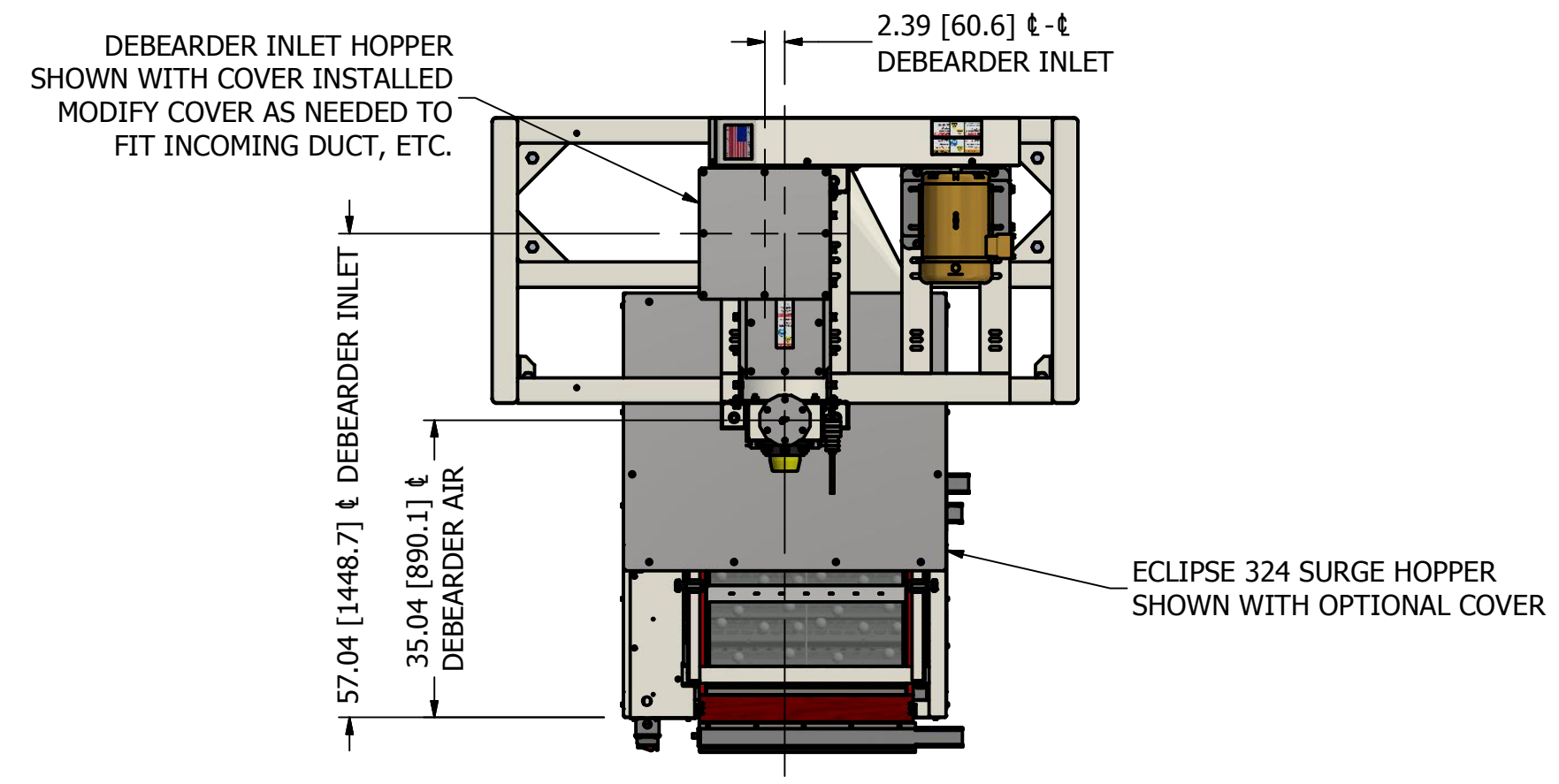
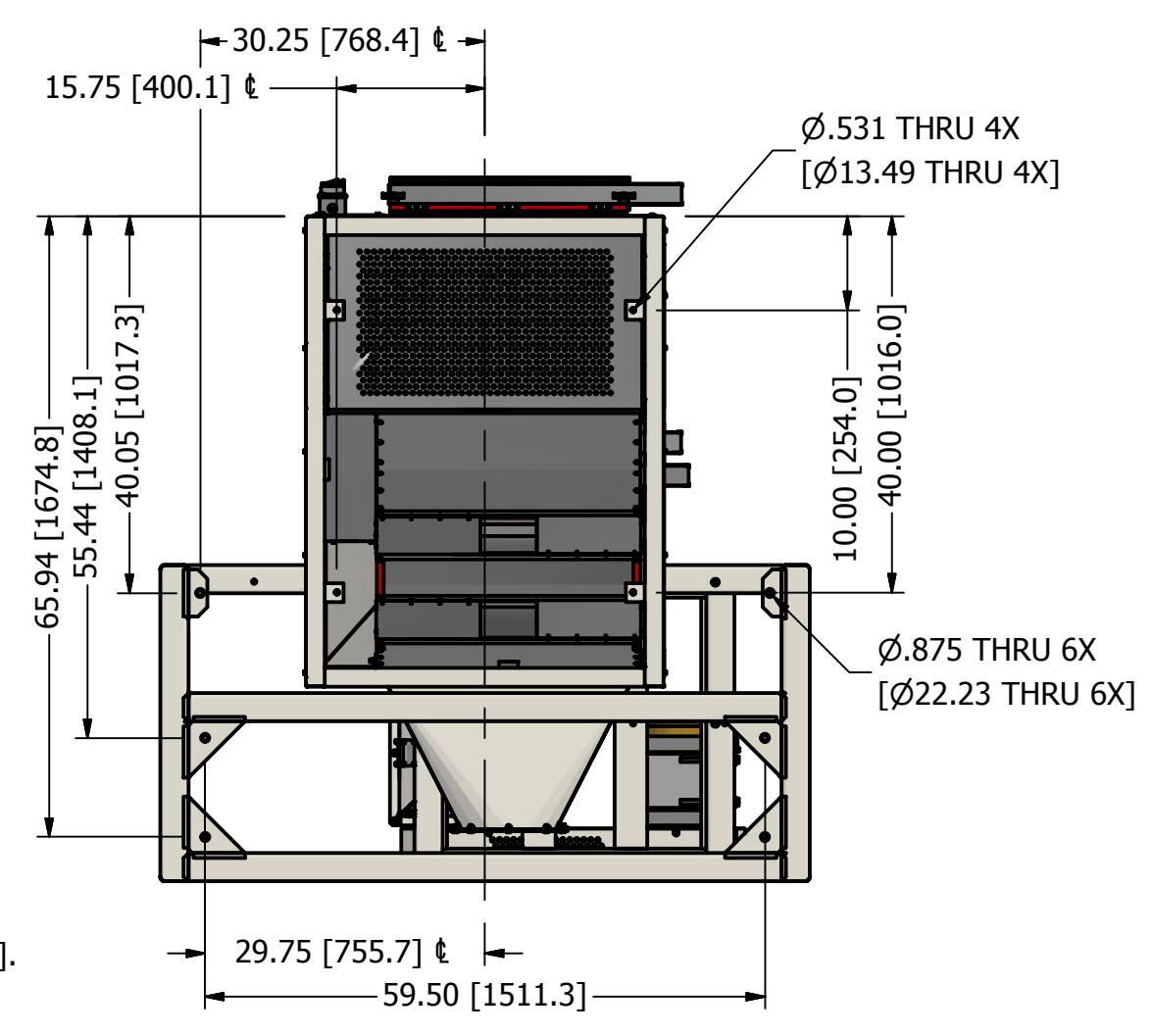

- NOTES:
 1. DO NOT SCALE FROM DRAWING.
 2. ALTERNATIVE DIMENSIONS [X.X] IN MILLIMETERS.
 3. INSTALLED WEIGHT AS SHOWN (3HP 208-230/460V 3Ø 60HZ MOTOR) 2675 LBS [1213 KG].
 4. RECOMMENDED MINIMUM MAINTENANCE CLEARANCE: FRONT, REAR & ONE SIDE: 24.00 [610]; SHAFT REMOVAL SIDE: 40.00 [1016].
 5. FASTEN DEBEARDER STAND TO FLOOR USING PROVIDED MOUNTING HOLES & Ø3/4" [Ø20] GRADE 8 FASTENERS.
 6. REFERENCE INSTALLATION PRINTS F20504120-1 SHEETS 1 & 2 AND F600000000-1 FOR SPECIFIC MACHINE DETAILS.

	DIVISION OF A.T.FERRELL COMPANY 1440 S ADAMS ST BLUFFTON, INDIANA 46714 - USA PH: 260-824-3400 FAX: 260-824-5463	This drawing is the property of the A. T. Ferrell Company, Inc and must be returned immediately upon request. No part of this drawing may be reproduced, stored in a retrieval system or transmitted in any form or by any means, without prior written consent of the A. T. Ferrell Company, Inc.
	DRAWN BY: dcclark DRAWN DATE: 11/15/2011 APPROVED BY: DMJ	
TOLERANCES EXCEPT AS NOTED DECIMAL: ± .030 FRACTIONAL: ± 1/32 XXX ± .005 XXXX ± .001	TITLE: HOUSING INSTALLATION, RH BASE & GUARD, DEBEARDER MINI	
CAD NO MANUAL CHANGES	SCALE: 1:8 SHEET: 3 OF 3 SIZE: D PART NUMBER: F20504120-I	REV: B