

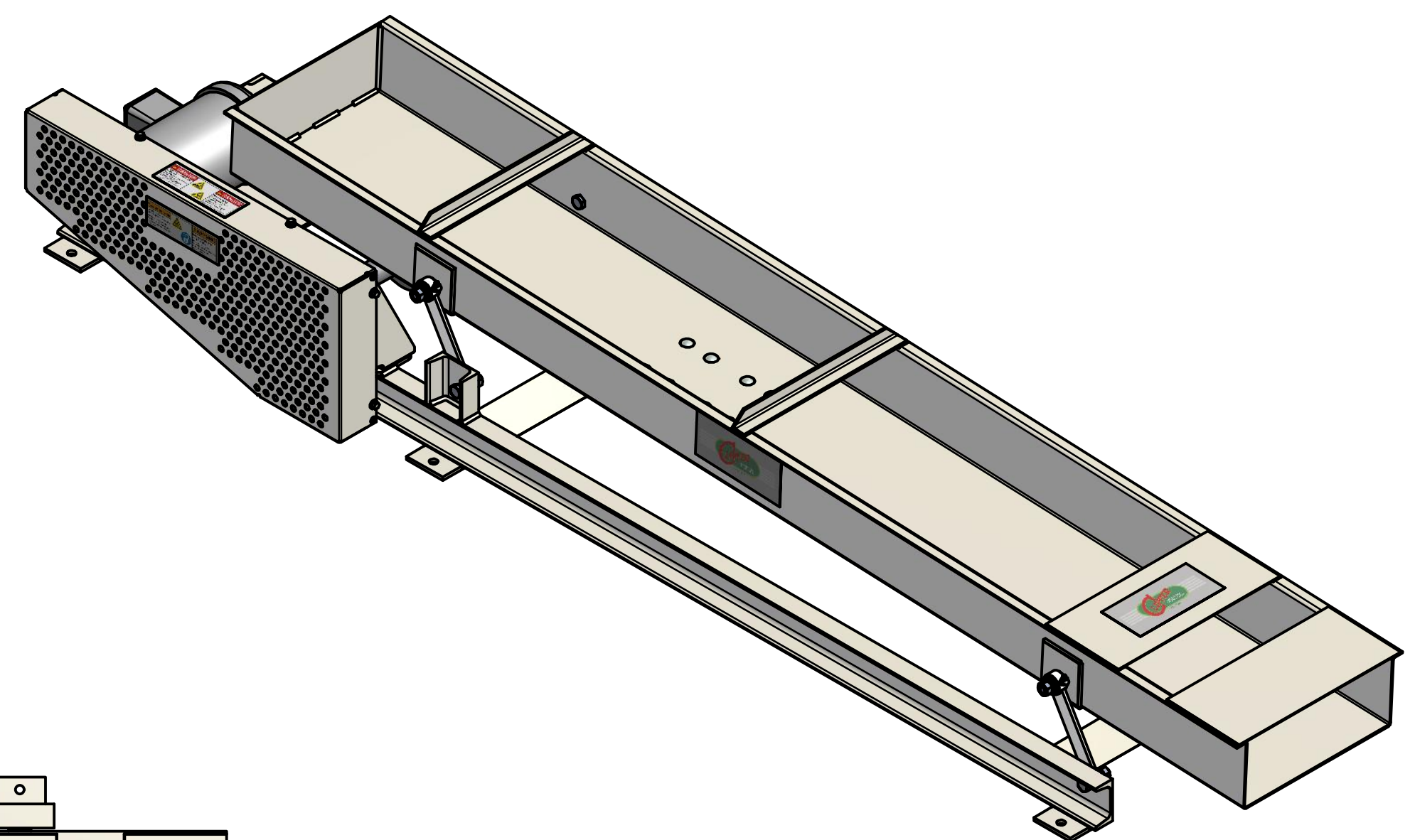

REV	ECN	DESCRIPTION	DATE	APPROVED
A	F150020	RELEASE	2/9/2015	dmjohnson

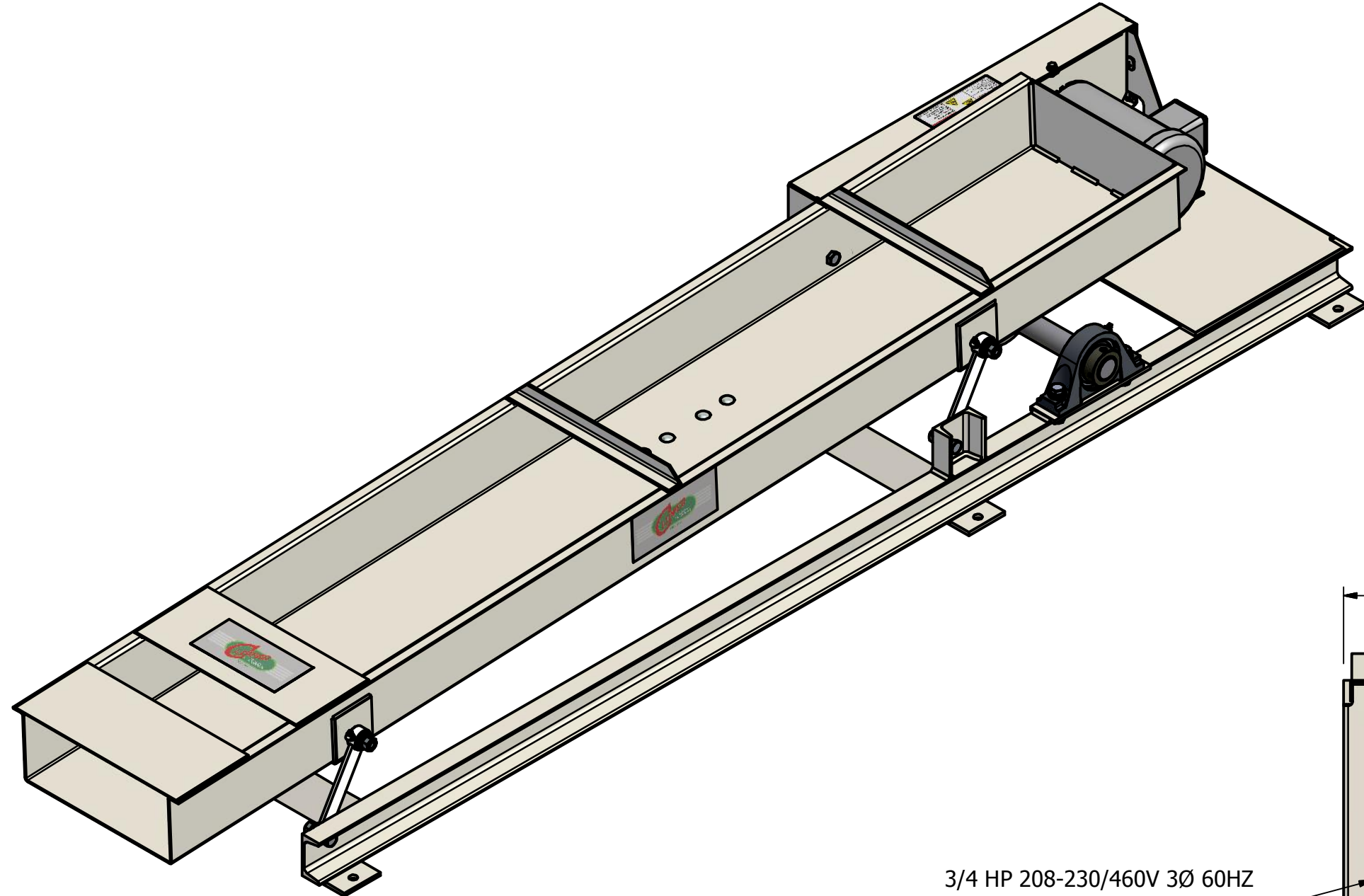

3/4 HP 208-230/460V 3Ø 60HZ
 TEFC 56T 3.2-3/1.5 FLA MOTOR
 SHOWN, NO RIGID CONNECTION

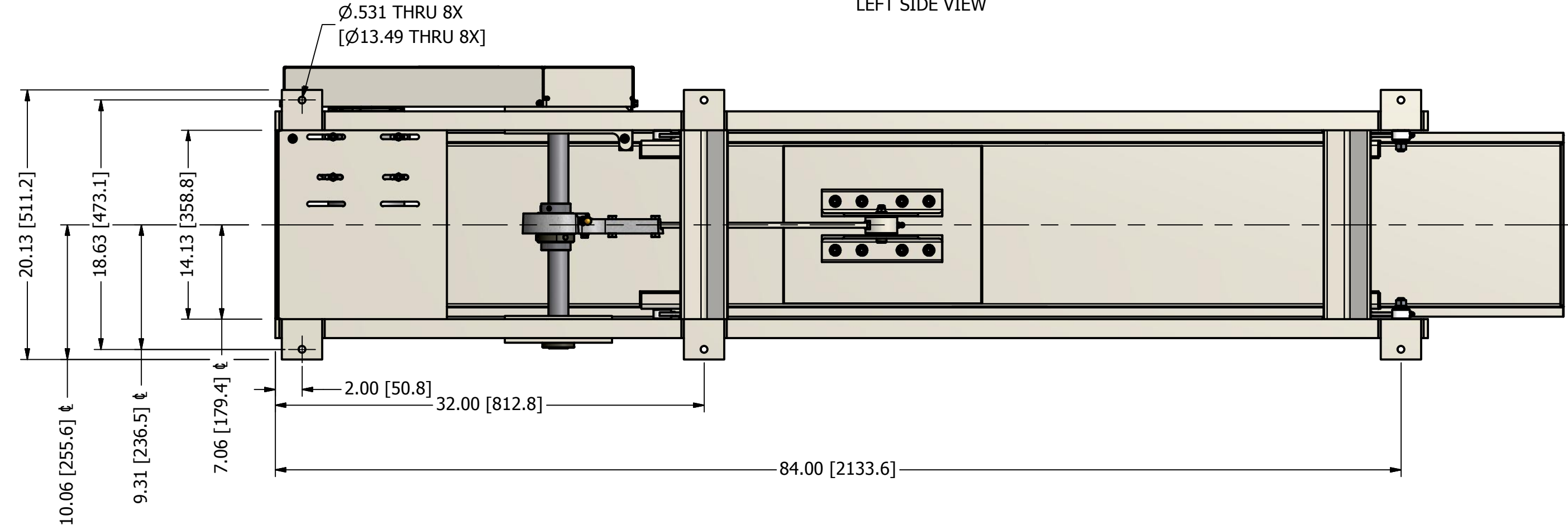
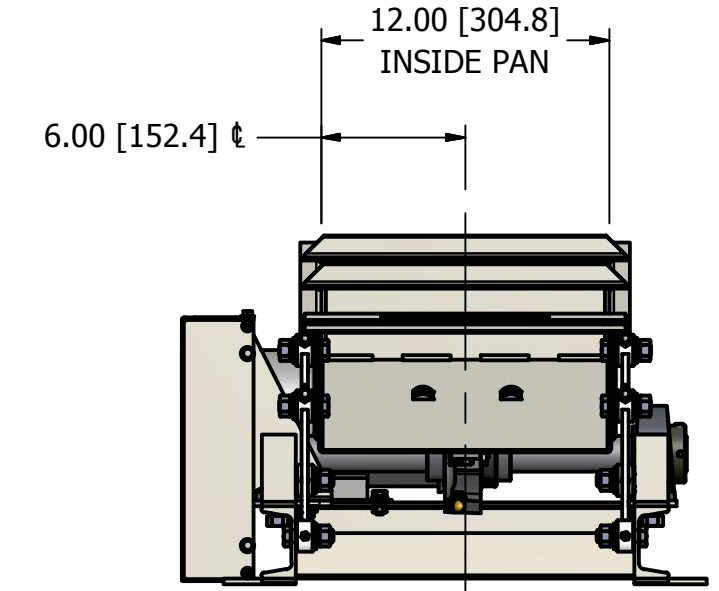
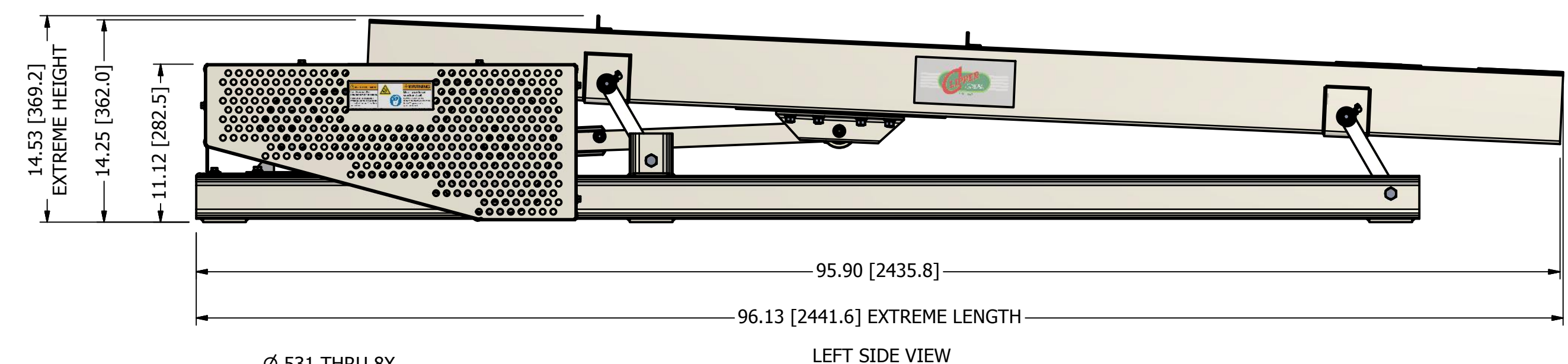
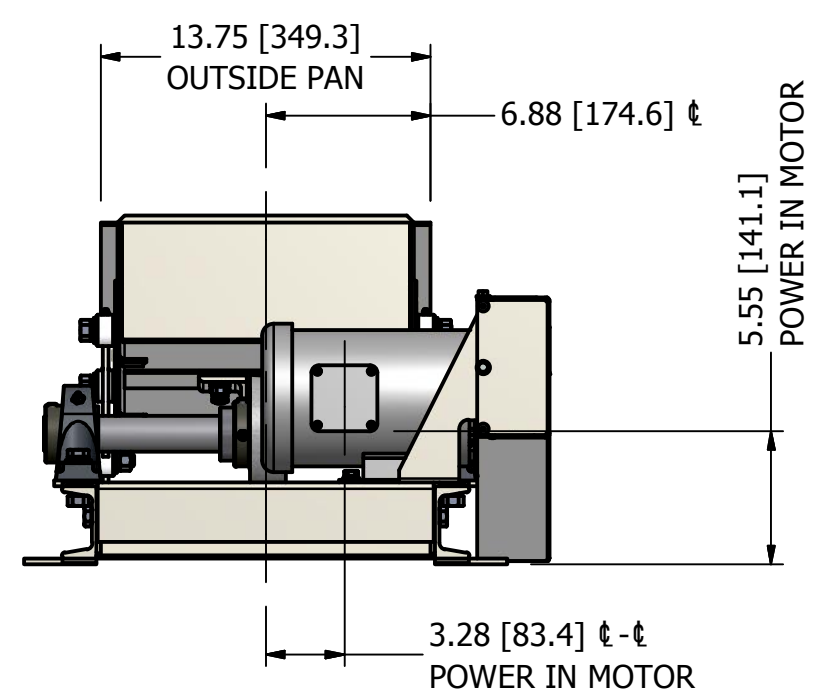
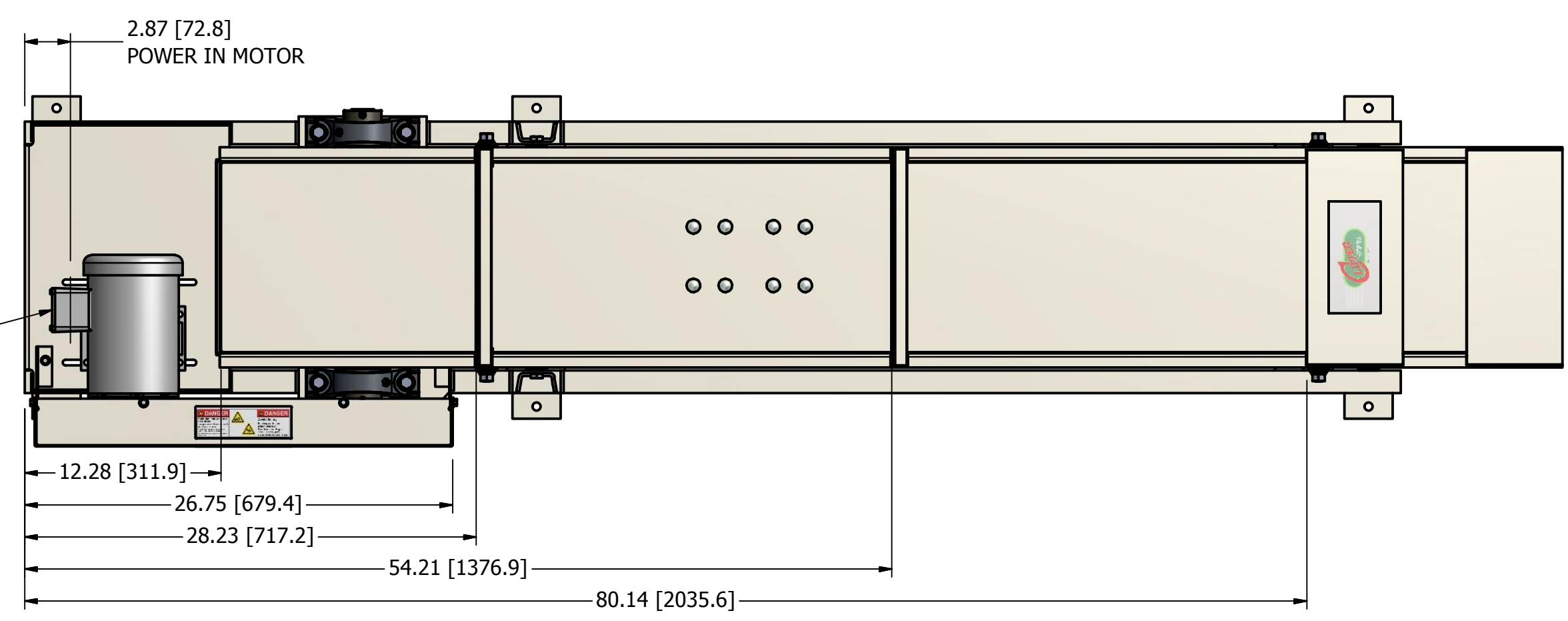

- NOTES:
- DO NOT SCALE FROM DRAWING.
 - ALTERNATIVE UNITS [X.X] IN MILLIMETERS.
 - WEIGHT: 275 LBS / 125 kg AS SHOWN.
 - PAN THROW: .375 [9.53] TOTAL.
 - COMPOSITION; FRAME ASTM 36 OR EQUIVALENT MILD STEEL, PAN ASTM A569 CQ HR MILD STEEL. ALL COMPONENTS PAINTED.

	DIVISION OF A.T.FERRELL COMPANY 1440 S ADAMS ST BLUFFTON, INDIANA 46714 - USA PH: 260-824-3400 FAX: 260-824-5463		This drawing is the property of the A. T. Ferrell Company, Inc and must be returned immediately upon request. No part of this drawing may be reproduced, stored in a retrieval system or transmitted in any form or by any means, without prior written consent of the A. T. Ferrell Company, Inc.		
	TOLERANCES EXCEPT AS NOTED DECIMAL: XX ± .030 XXX ± .005 XXXX ± .001	FRACTIONAL: ± 1/32 ANGULAR: ± 1/2°	TITLE: CONVEYOR INSTALLATION, SUPER VIBRATORY, 12" X 7'	DRAWN BY: dmjohnson	DRAWN DATE: 2/9/2015
CAD NO MANUAL CHANGES	SCALE: 1:8	SHEET: 1 OF 1	SIZE: D	PART NUMBER: F51001207-1	REV: A