

REVISION HISTORY				
REV	ECN	DESCRIPTION	DATE	APPROVED
A	K040041	RELEASE	9/3/2004	pggalea
B	K090077	REDRAWN IN INVENTOR, WAS D-SIZE	3/20/2009	pggalea
C	K110239	REMOVED BRG SPACER FORM DRIVE END	11/8/2011	SH

BEARING MOUNTING & DISMOUNTING INSTRUCTIONS:

1. PRECAUTIONS:

- A. MOUNT THE BEARINGS IN A CLEAN ENVIRONMENT. HOUSINGS, SHAFTS AND OTHER COMPONENTS OF THE BEARING ARRANGEMENT SHOULD BE CHECKED FOR CLEANLINESS.
- B. THE BEARINGS SHOULD BE LEFT IN THEIR ORIGINAL PACKAGES UNTIL IMMEDIATELY BEFORE MOUNTING, SO THAT THEY DO NOT BECOME DIRTY.
- C. THE DIMENSIONAL AND FORM ACCURACY ALL COMPONENTS WHICH WILL BE IN CONTACT WITH THE BEARING SHOULD BE CHECKED.
- D. CHECK THE DIAMETER OF THE ROLL JOURNAL BEARING MOUNT SURFACE USING A MICROMETER AT FOUR POSITIONS IN THREE PLANES. 2.938 +/-0.001 [74.63 +/-0.025].
- E. CHECK THE DIAMETER OF THE BEARING HOUSING BEARING MOUNT SURFACE USING AN INTERNAL GAUGE AT FOUR POSITIONS IN THREE PLANES. 5.906 +/-0.001-0 [150.01 +/-0.025/-0].
- F. USE LIFTING EQUIPMENT TO FACILITATE THE HANDLING OF THE BEARING. SPRING SUSPENSION CAN SIMPLIFY BEARING POSITIONS.

2. MOUNTING PROCEDURE:

- A. WIPE THE PRESERVATIVE FROM THE BORE AND OUTSIDE DIAMETER OF THE BEARING. WIPE THE PRESERVATIVE FROM THE SURFACES OF THE ADAPTER SLEEVE.
- B. LIGHTLY OIL THE BORE AND OTHER RACE OF THE BEARING WITH A THIN MINERAL OIL.
- C. OPEN THE ADAPTER SLEEVE BY INSERTING A SCREWDRIVER OR OTHER SUITABLE TOOL IN THE SLIT (DO NOT SCRATCH THE JOURNAL) AND SLIDE THE SLEEVE ALONG THE ROLL JOURNAL TO THE COLLAR.
- D. GENTLY DRIVE THE BEARING INTO THE BEARING HOUSING UNTIL THE BEARING BOTTOMS IN THE HOUSING BORE. GENTLY STRIKE AROUND THE BEARING OUTER RACE EQUALLY WITH A RUBBER Mallet.
- E. POSITION THE ROLL ON SADDLE BLOCKS AND SLIDE THE DUST SEALS OVER THE ROLL JOURNALS, ON TO THE ROLL COLLARS.
- F. GENTLY DRIVE THE INNER OIL SEAL INTO THE BEARING HOUSING BY TAPPING EQUALLY AROUND THE SEAL WITH A RUBBER Mallet UNTIL FLUSH WITH THE HOUSING.
- G. SLIDE THE BEARING HOUSING OVER THE ROLL JOURNAL AND INTO THE ADAPTER SLEEVE. LOCATE THE HOUSING MOUNTING HOLES 3.00 [76.2] FROM THE ROLL FACE.
- H. SCREW ON THE BEARING LOCK NUT WITH ITS CHAMFER FACING THE BEARING, BUT DO NOT MOUNT THE LOCKING WASHER.
- I. REMOVE THE SADDLE BLOCKS FROM THE ASSEMBLY END OF THE ROLL SO THAT THE BASE OF THE BEARING HOUSING IS SETTING ON THE FLOOR.
- J. MEASURE THE BEARING RESIDUAL CLEARANCE USING FEELER GAUGES BETWEEN THE OUTER RING AND THE UPPER MOST (UNLOADED ROLLER). BEFORE MEASURING, THE BEARING SHOULD BE ROTATED A FEW TIMES TO ENSURE THAT THE ROLLERS HAVE ASSUMED THEIR CORRECT POSITION. DURING MEASUREMENT, THE ROLLER AT THE MEASURING POINT SHOULD BE LIGHTLY PRESSED AGAINST THE GUIDE RING BETWEEN THE TWO ROLLERS ROWS AND THE FEELER GAUGE BLADE IS INSERTED TO THE MIDDLE OF THE ROLLER. TIGHTEN THE LOCK NUT WITH A SPANNER WRENCH UNTIL THE CORRECT RESIDUAL RADIAL CLEARANCE IS REACHED. THE RESIDUAL CLEARANCE SHOULD BE A MINIMUM OF .0014 [.0356] AND A MAXIMUM OF .0020 [.0508].
- K. UNSCREW THE LOCK NUT. THE BEARING WILL NOT COME LOOSE.
- L. PLACE THE BEARING LOCK WASHER IN POSITION. TIGHTEN THE LOCK NUT FIRMLY, BUT MAKE SURE THAT THE BEARING IS NOT DRIVEN ANY FURTHER UP THE SLEEVE.
- M. LOCK THE NUT BY BENDING ONE OF THE LOCKING WASHER TABS DOWN INTO ONE OF THE SLOTS IN THE NUT. DO NOT BEND THE TAB TO THE BOTTOM OF THE SLOT.
- N. CHECK THAT THE ROLL JOURNAL ROTATES WITHOUT ANY DISTURBANCES.
- O. PLACE SPACER RING INSIDE BEARING HOUSING, AGAINST BEARING OUTER RACE.
- P. GENTLY DRIVE THE OUTER OIL SEAL INTO THE BEARING COVER BY TAPPING EQUALLY AROUND THE SEAL WITH A RUBBER Mallet UNTIL FLUSH WITH THE COVER.
- Q. SLIDE THE COVER OVER THE ROLL JOURNAL AND FASTEN TO THE BEARING HOUSING.
- R. FILL BEARING HOUSING WITH GREASE, SEE NOTES.
- S. REPEAT PROCEDURE FOR OPPOSITE BEARING HOUSING.

3. DISMOUNTING PROCEDURE:

- A. REMOVE THE BEARING HOUSING COVER.
- B. DISENGAGE THE TAB OF THE LOCK WASHER FROM THE LOCK NUT.
- C. LOOSEN (TURN COUNTERCLOCKWISE) THE LOCK NUT WITH A SPANNER WRENCH OR SOFT STEEL BAR AND HAMMER. LOOSEN NUT A FEW TURNS, BUT LEAVE ON SLEEVE.
- D. USE A PIECE OF 3.00 ID [76.2] MINIMUM THICK WALL TUBING OR PIPE, LONG ENOUGH TO REACH THE ADAPTER OVER THE DRIVE JOURNAL WITH A PLATE WELDED OVER ONE END TO LOOSEN THE ADAPTER.
- E. PLACE THE PIPE AGAINST THE END OF THE BEARING ADAPTER AND STRIKE THE PIPE SQUARELY, DRIVING THE ADAPTER INSIDE OF THE JOURNAL COLLAR.
- F. THE BEARING HOUSING, BEARING AND ADAPTER WILL SLIP EASILY OFF THE ROLL JOURNAL.

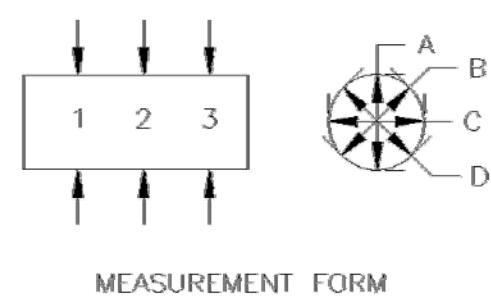
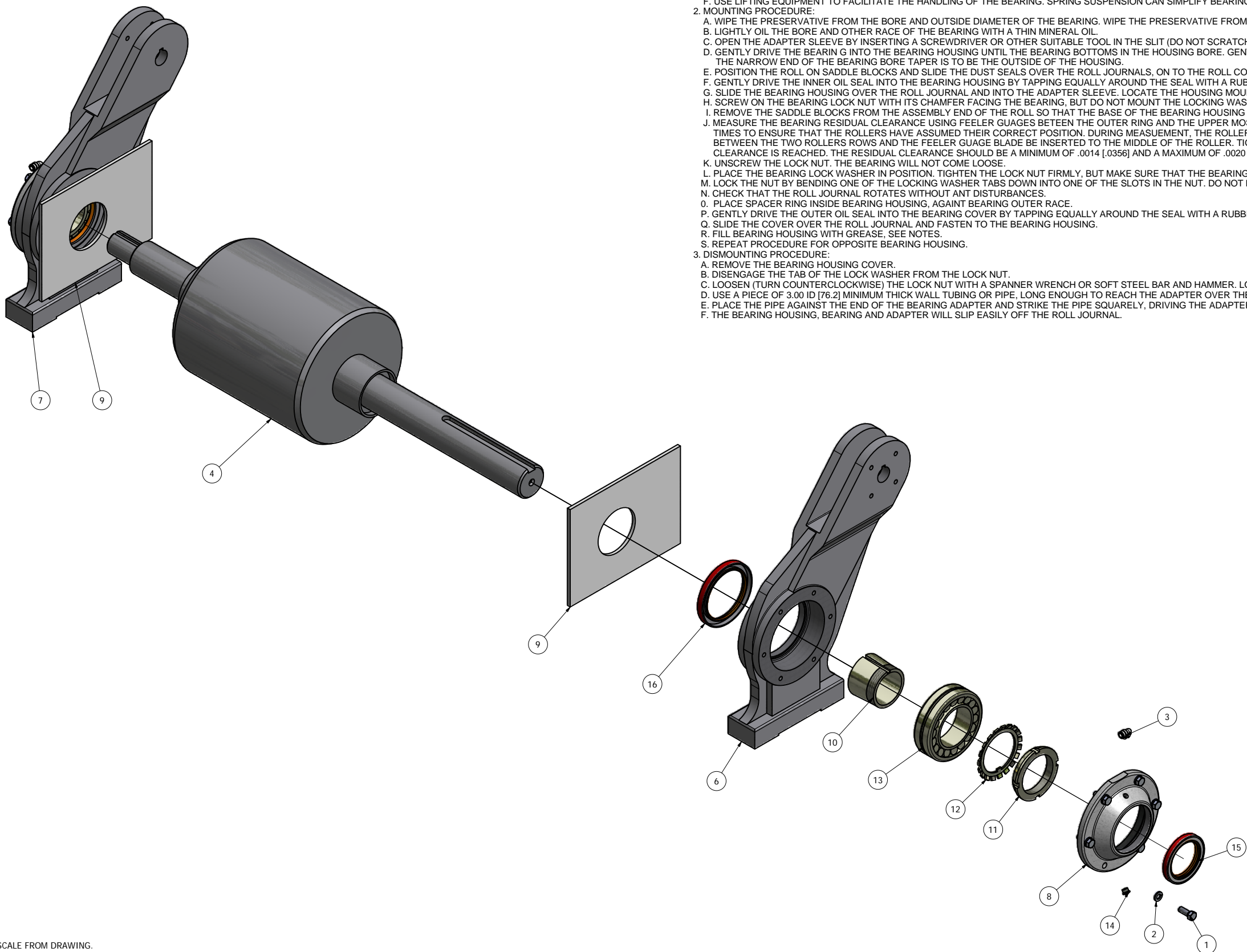

MEASUREMENT FORM

- NOTES:**
- 1. DO NOT SCALE FROM DRAWING.
 - 2. ONE PIECE REQUIRED PER K000-01230: ROLLER MILL ASSY, SINGLE RH RF 1.5:1, 10 X 12".
 - 3. ONE PIECE REQUIRED PER K000-01236: ROLLER MILL ASSY, SINGLE RH VF 1.5:1, 10 X 12".
 - 4. TWO PIECES REQUIRED PER K000-01250: ROLLER MILL ASSY, 2 HI RH RF 1.5:1, 10 X 12".
 - 5. FILL BEARING HOUSING WITH NLGI No. 2 GRADE LITHIUM BASED GREASE WITH AT LEAST 1000 SSU @ 100° F UNTIL GREASE RELIEFS OPEN. APPROXIMATELY 56 FL OZ (4, 14 OZ TUBES), AFTER ASSEMBLY COMPLETE.

ITEM	PART NUMBER	QTY	DESCRIPTION
16	K914-06201	2	SEAL, OIL 415991
15	K914-05901	2	SEAL, NATIONAL 411245
14	K910-06221	2	FITTING, RELIEF-ALEMITE 317-400 1/8-27 NPT
13	K902-13801	2	BEARING, SPHERICAL 22215-KC3
12	K902-10501	2	LOCKWASHER, BEARING ADAPTER W 15
11	K902-10501	2	LOCKNUT, BEARING ADAPTER AN 15
10	K902-10501	2	SLEEVE, BEARING ADAPTER ASK 15
9	K200-05534	2	SEAL, DUST 3.500"DIA 10"
8	K200-01906	2	COVER, BEARING HOUSING, FIXED 215-4
7	K200-01903	1	HOUSING, BEARING, FIXED 215-1- L
6	K200-01902	1	HOUSING,BEARING, FIXED 215-1-R
5	K200-01627	1	SPACER, BEARING .13" X 215/217
4	K200-01280	1	ROLL ASSY, DRIVE FIN 2.438" 10 X 12"
3	70012050	2	CPLG, ELBOW 90 1/8-27M NPT X 1/4" TBG
2	66444400	12	WASHER, LOCK HELICAL 3/8"
1	62584422	12	HHCS, 3/8-16 X 1.00"

	DIVISION OF A.T.FERRELL COMPANY 1440 S ADAMS ST BLUFFTON, INDIANA 46714 - USA PH: 260-824-3400 FAX: 260-824-5463	This drawing is the property of the A.T. Ferrell Company, Inc and must be returned immediately upon request. No part of this drawing may be reproduced, stored in a retrieval system or transmitted in any form or by any means, without prior written consent of the A.T. Ferrell Company, Inc.	
	SINCE 1869	DRAWN BY: pggalea	DRAWN DATE: 3/20/2009
TOLERANCES EXCEPT AS NOTED DECIMAL: .030 .005 .001	FRACTIONAL: 1/32 FINISH: ANGLAR: 1/2"	TITLE: ROLL & BRNG HSG ASSY, FIXED 10 X 12"	
CAD NO MANUAL CHANGES	SCALE: 0.38:1	SHEET: 2 OF 2	SIZE: D
PART NUMBER: K100-00162		REV: C	