

REVISION HISTORY					
REV	LTR	ZONE	DESCRIPTION	DATE	APPROVED
A	K010075	1	RELEASE	6/19/2001	pggalea
B	K070042	1	REDRAWN INVENTOR	3/27/2007	dmjohnson

BEARING MOUNTING & DISMOUNTING INSTRUCTIONS:

1 PRECAUTIONS:

- A. MOUNT THE BEARINGS IN A CLEAN ENVIRONMENT. HOUSINGS, SHAFTS AND OTHER COMPONENTS OF THE BEARING ARRANGEMENT SHOULD BE CHECKED FOR CLEANLINESS.
- B. THE BEARINGS SHOULD BE LEFT IN THEIR ORIGINAL PACKAGES UNTIL IMMEDIATELY BEFORE MOUNTING, SO THAT THEY DO NOT BECOME DIRTY.
- C. THE DIMENSIONAL AND FORM ACCURACY ALL COMPONENTS WHICH WILL BE IN CONTACT WITH THE BEARING SHOULD BE CHECKED.
- D. CHECK THE DIAMETER OF THE ROLL JOURNAL BEARING MOUNT SURFACE USING A MICROMETER AT FOUR POSITIONS IN THREE PLANES. 5.9077 +/- .0005 [150.056 +/- .013].
- E. CHECK THE DIAMETER OF THE BEARING HOUSING BEARING MOUNT SURFACE USING AN INTERNAL GAUGE AT FOUR POSITIONS IN THREE PLANES. 12.5998 +/- .0014 [320.035 +/- .036].
- F. USE LIFTING EQUIPMENT TO FACILITATE THE HANDLING OF THE BEARING. SPRING SUSPENSION CAN SIMPLIFY BEARING POSITIONS.

2. MOUNTING PROCEDURE:

- A. GENTLY DRIVE THE INNER OIL SEAL INTO BOTH BEARING HOUSING COVERS BY TAPPING EQUALLY AROUND THE SEAL WITH A RUBBER Mallet UNTIL FLUSH WITH THE HOUSING.
- B. SLIDE THE BEARING HOUSING COVERS OVER EACH JOURNAL, UP TO THE ROLL END.
- C. WIPE THE PRESERVATIVE FROM THE BORE AND OUTSIDE DIAMETER OF THE BEARING.
- D. HEAT THE BEARING USING AN INDUCTION HEATER. AN ELECTRIC OVEN MAY BE USED IF BEARING PLACED ON SUPPORTS SO THAT AIR CAN MOVE FREELY AROUND BEARING.
- E. NORMALLY A BEARING TEMPERATURE OF 144 TO 162 °F [80 TO 90 °C] ABOVE THAT OF THE SHAFT IS SUFFICIENT FOR MOUNTING. NEVER HEAT A BEARING GREATER THAN 257 °F [125 °C], OR USING AN OPEN FLAME.
- F. USE CLEAN PROTECTIVE GLOVES TO HANDLE THE HOT BEARING.
- G. PUSH THE BEARING ALONG THE ROLL JOURNAL TO ITS ABUTMENT AND HOLD IN PLACE WITH THE BEARING LOCK NUT UNTIL THE BEARING COOLS AND GRIPS THE JOURNAL. REMOVE THE LOCK NUT.
- H. SLIDE THE BEARING LOCK WASHER AGAINST THE OUTSIDE OF THE BEARING. LOCK WASHER FINGERS POINT AWAY FROM THE BEARING. LOCK WASHER INNER TONGUE FITS INTO JOURNAL KEYWAY.
- I. FIRMLY TIGHTEN THE LOCK NUT, CHAMFER TOWARD THE LOCK WASHER. USE A SPANNER WRENCH OR SOFT METAL ROD AND HAMMER.
- J. LOCK THE NUT BY BENDING ONE OF THE LOCKING WASHER TABS DOWN INTO ONE OF THE SLOTS IN THE NUT. DO NOT BEND THE TAB TO THE BOTTOM OF THE SLOT.
- K. CHECK THAT THE BEARING OUTER RACE ROTATES WITHOUT ANY DISTURBANCES AND THAT THE INNER RACE IS HELD IN PLACE.
- L. POSITION THE ROLL UP OFF OF THE FLOOR ON SADDLE BLOCKS.
- M. USE A PAIR OF C-CLAMPS TO DRAW THE BEARING HOUSING OVER THE BEARING. CLAMP THE COVER TO THE OUTSIDE OF THE HOUSING AND DRAW IN EQUALLY. LOCATE THE HOUSING MOUNTING HOLES 6.50 [165.10] FROM THE ROLL END.
- N. GENTLY DRIVE THE OUTER OIL SEAL INTO THE DRIVE JOURNAL BEARING HOUSING BY TAPPING EQUALLY AROUND THE SEAL WITH A RUBBER Mallet UNTIL FLUSH WITH THE HOUSING.
- O. GENTLY DRIVE THE SEAL ADAPTER INTO THE DIFFERENTIAL JOURNAL BEARING HOUSING BY TAPPING EQUALLY AROUND THE ADAPTER WITH A RUBBER Mallet UNTIL FLUSH WITH THE HOUSING.
- P. REPEAT STEP 'N' FOR INSTALLING OUTER SEAL INTO ADAPTER.
- Q. FASTEN TO THE BEARING HOUSING WITH 1/2" FASTENERS.
- R. FILL BEARING HOUSING WITH GREASE. SEE NOTES.
- S. REPEAT PROCEDURE FOR OPPOSITE BEARING HOUSING.
- T. WRAP THE THREADS OF THE STINGER WITH PIPE TAPE AND SCREW INTO THE ROTARY UNION.
- U. WRAP THE EXTERNAL THREADS OF THE ROTARY UNION WITH PIPE TAPE AND SCREW INTO THE STUB JOURNAL.

3. DISMOUNTING PROCEDURE:

- A. REMOVE THE 1/2" FASTENERS HOLDING THE COVER TO THE BEARING HOUSING.
- B. THE BEARING HOUSING WILL SLIDE OVER THE BEARING.
- C. DISENGAGE THE TAB OF THE BEARING LOCK WASHER FROM THE BEARING LOCK NUT.
- D. LOOSEN (TURN COUNTERCLOCKWISE) THE BEARING LOCK NUT WITH A SPANNER WRENCH OR SOFT METAL BAR AND HAMMER. REMOVE THE LOCK NUT AND LOCK WASHER.
- E. REMOVE THE BEARING FROM THE JOURNAL WITH A BEARING PULLER.
- F. REMOVE THE COVER FROM THE JOURNAL.

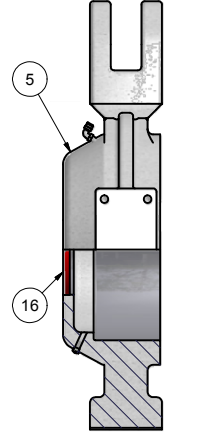
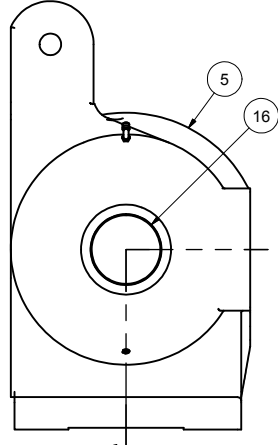
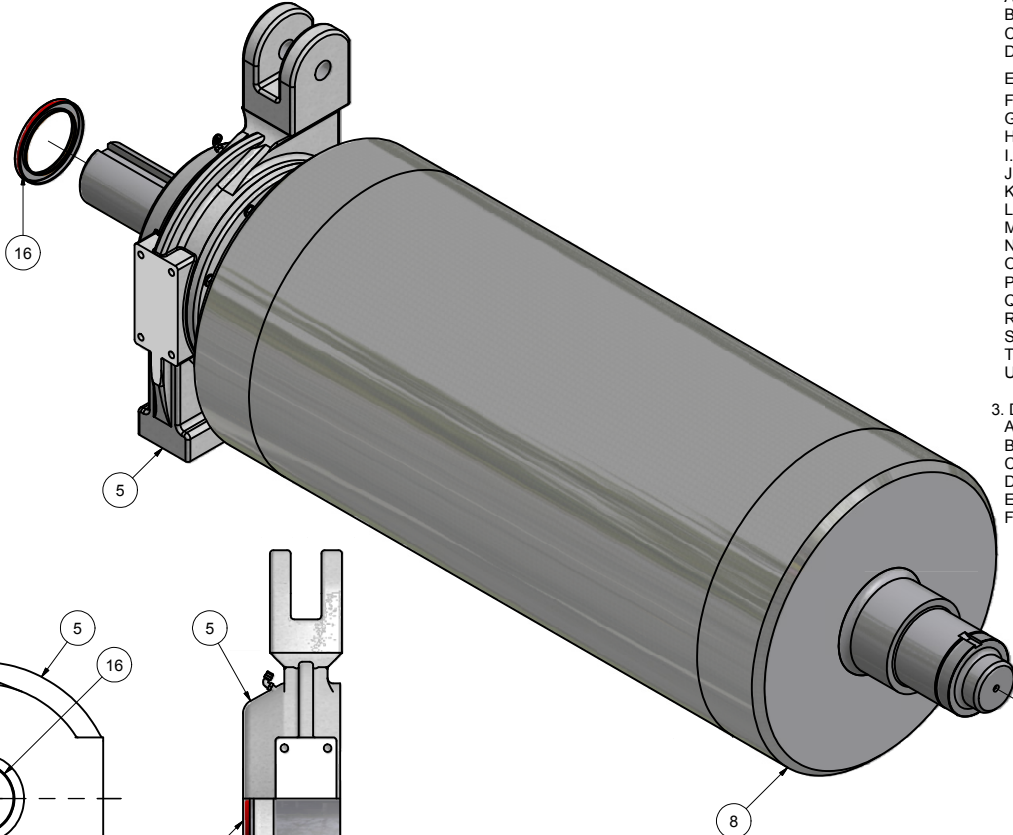

BEARING HOUSING ASSY DRIVE JOURNAL

SECTION A-A SCALE 0.15 : 1

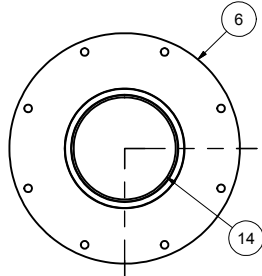
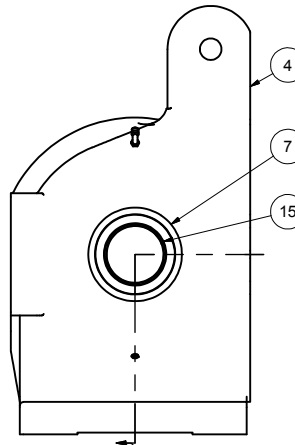

BEARING HOUSING ASSY STUB JOURNAL

SECTION B-B SCALE 0.15 : 1

COVER ASSEMBLY

SECTION C-C SCALE 0.15 : 1

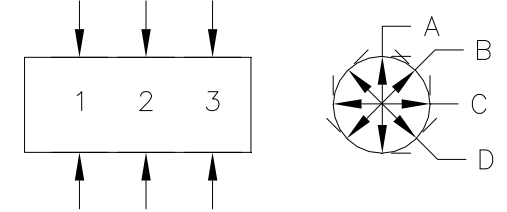
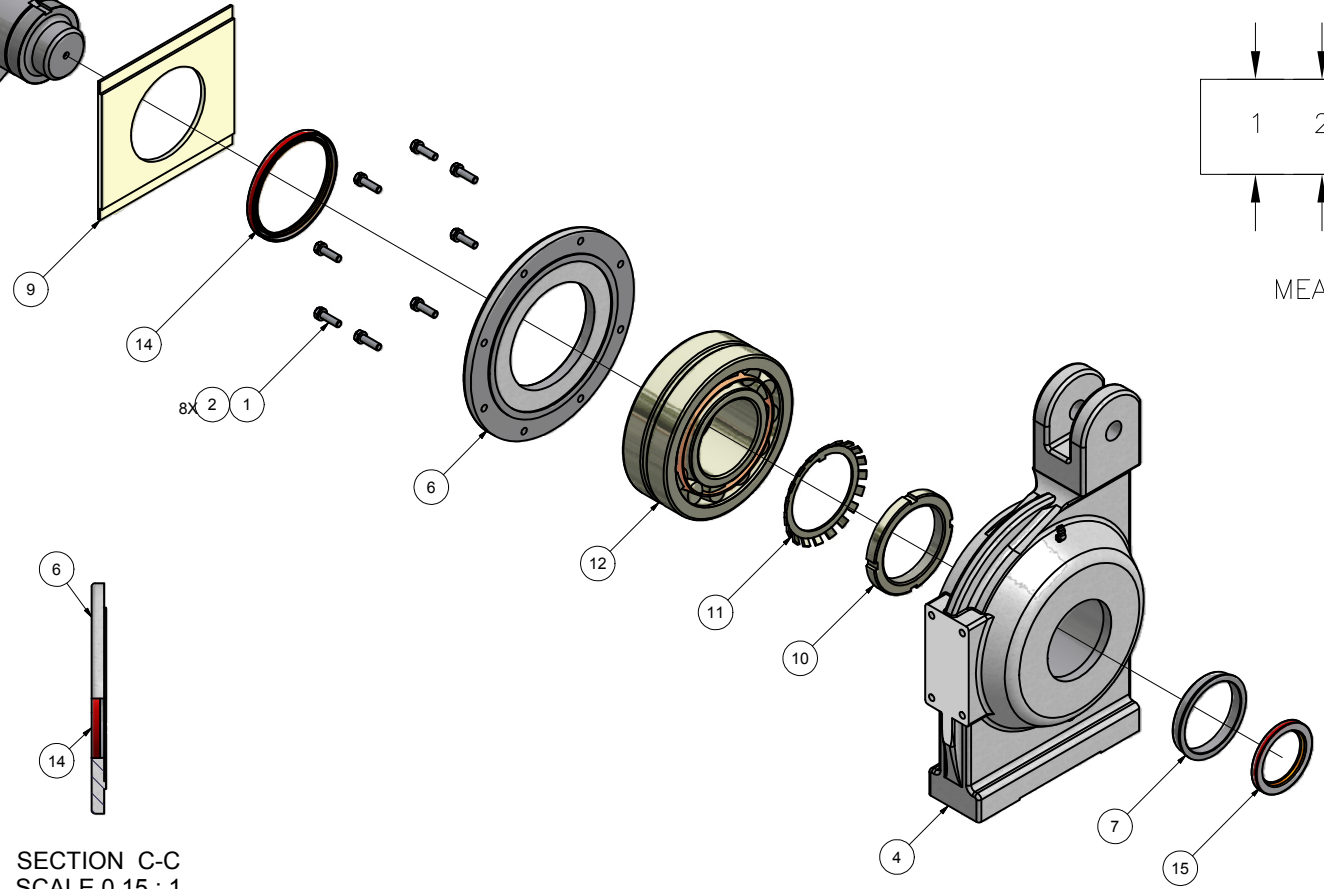

MEASUREMENT FORM

- NOTES:
- DO NOT SCALE FROM DRAWING.
 - ONE PC REQ'D PER K000-02456: ROLLER MILL, DUAL DRIVE FL 24 X 56".
 - SIMILAR TO K100-02412: ROLL & BEARING HOUSING ASSY, PIVOT DUAL DRIVE FL 24 X 56".
 - SEE SHEET 1 FOR GENERAL ASSEMBLY DETAILS.
 - FILL BEARING HOUSINGS WITH NLGI No. 2 GRADE LITHIUM BASED GREASE WITH AT LEAST 1000 SSU @ 100°F UNTIL GREASE RELIEFS OPEN, APPROXIMATELY 98 FL OZ (7, 14 OZ TUBES).

ITEM	PART NUMBER	QTY	DESCRIPTION
16	K914-07501	1	SEAL, OIL 415066
15	K914-06501	1	SEAL, OIL 417506
14	K914-06027	2	SEAL, OIL 416044
13	K910-06221	2	FITTING, RELIEF-ALEMITE 317-400 1/8-27 NPT
12	K902-14601	2	Spherical Roller 22330 CC/W33
11	K902-12901	2	WASHER, LOCK BEARING W-30
10	K902-01501	2	NUT, LOCK BEARING AN-30
9	K200-05860	2	SEAL, DUST 7.250" JNRL, DUAL DRV 24" FL
8	K200-05842	1	ROLL ASSY, DUAL DRIVE FL 24 X 56"
7	K200-02077	1	ADAPTER, SEAL, FIXED HSG, DIFF JRNL 24"
6	K200-02062	2	COVER, BEARING HOUSING, FIXED 330-4
5	K200-02059	1	HOUSING, BEARING FIXED LEFT 330 24"
4	K200-02058	1	HOUSING, BEARING FIXED RIGHT 330 24"
3	70012050	2	CPLG, ELBOW 90 1/8-27M NPT X 1/4" TBG
2	66445200	16	WASHER, LOCK HELICAL 1/2"
1	62585230	16	HHCS, 1/2-13 X 1.75"

This drawing is the property of the A.T. Ferrell Company, Inc and must be returned immediately upon request. No part of this drawing may be reproduced, stored in a retrieval system or transmitted in any form or by any means, without prior written consent of the A.T. Ferrell Company, Inc.

CAD
NO MANUAL CHANGES

TOLERANCES
EXCEPT AS NOTED

DECIMAL: .005
XX ± .030

FRACTIONAL: ± 1/32

ANGULAR: ± 1/2

FINISH: _____

SCALE: _____

DRAWN BY: dmjohnson

APPROVED BY: DMJ

TITLE: ROLL & BEARING HOUSING ASSY, FIXED DL DRV 24 X 56"

DATE: 3/27/2007

SIZE: D

PART NUMBER: K100-02413

SHEET: 2 of 2