

REVISION HISTORY				
REV	ECN	DESCRIPTION	DATE	APPROVED
A	K010132	RELEASED	4/20/2002	DJ
B	K110239	REMOVED BRG SPACER FROM STUB END	11/8/2011	SH

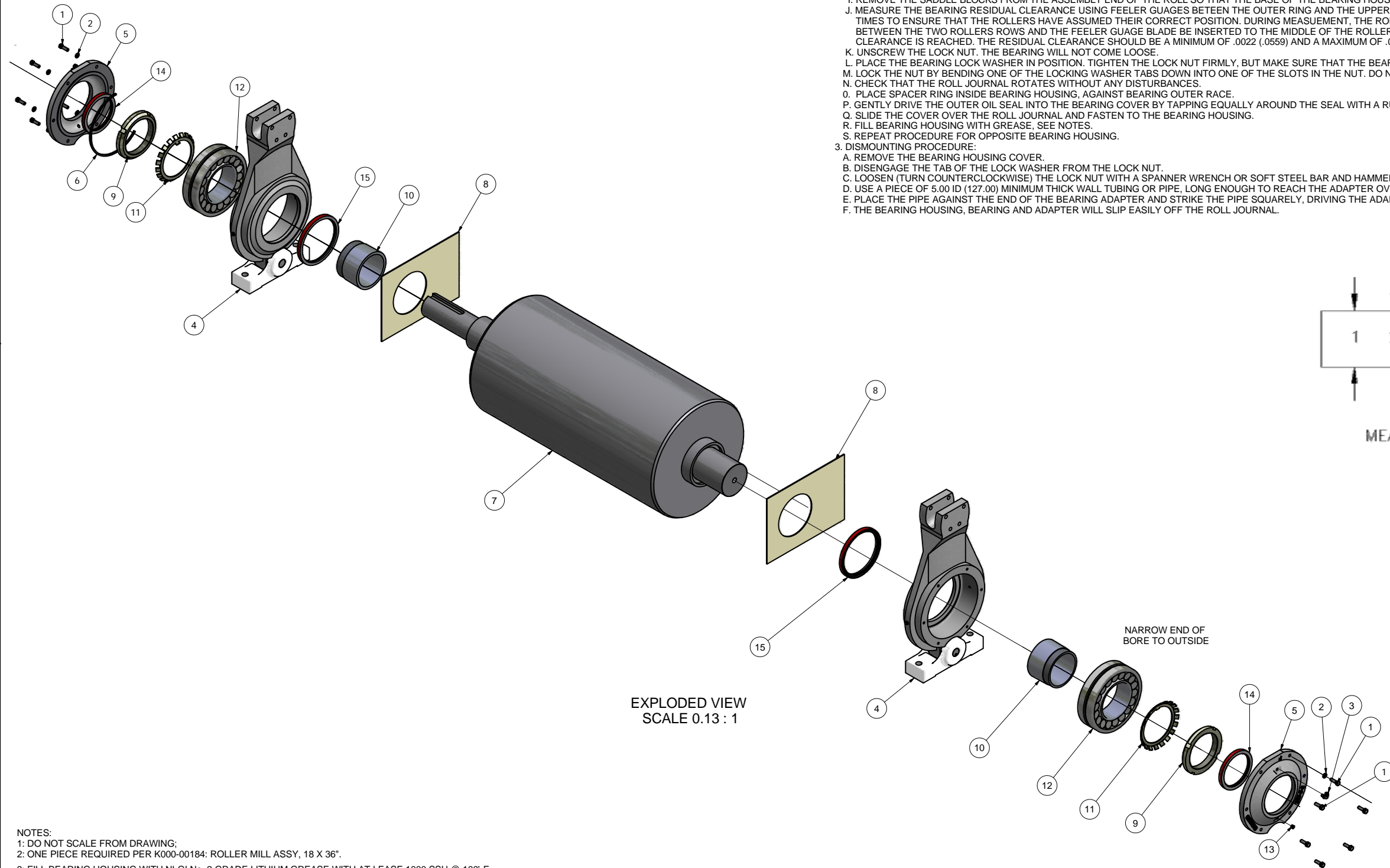

EXPLODED VIEW
SCALE 0.13 : 1

BEARING MOUNTING & DISMOUNTING INSTRUCTIONS:

- PRECAUTIONS:
 - MOUNT THE BEARINGS IN A CLEAN ENVIRONMENT. HOUSINGS, SHAFTS AND OTHER COMPONENTS OF THE BEARING ARRANGEMENT SHOULD BE CHECKED FOR CLEANLINESS.
 - THE BEARINGS SHOULD BE LEFT IN THEIR ORIGINAL PACKAGES UNTIL IMMEDIATELY BEFORE MOUNTING, SO THAT THEY DO NOT BECOME DIRTY.
 - THE DIMENSIONAL AND FORM ACCURACY ALL COMPONENTS WHICH WILL BE IN CONTACT WITH THE BEARING SHOULD BE CHECKED.
 - CHECK THE DIAMETER OF THE ROLL JOURNAL BEARING MOUNT SURFACE USING A MICROMETER AT FOUR POSITIONS IN THREE PLANES. 4.938 +0/- .001 (125.435 +0/- .025).
 - CHECK THE DIAMETER OF THE BEARING HOUSING BEARING MOUNT SURFACE USING AN INTERNAL GAUGE AT FOUR POSITIONS IN THREE PLANES. 9.843 +.001/-0 (250.012 +.025/-0).
 - USE LIFTING EQUIPMENT TO FACILITATE THE HANDLING OF THE BEARING. SPRING SUSPENSION CAN SIMPLIFY BEARING POSITIONS.
- MOUNTING PROCEDURE:
 - WIPE THE PRESERVATIVE FROM THE BORE AND OUTSIDE DIAMETER OF THE BEARING. WIPE THE PRESERVATIVE FROM THE SURFACES OF THE ADAPTER SLEEVE.
 - LIGHTLY OIL THE BORE AND OTHER RACE OF THE BEARING WITH A THIN MINERAL OIL.
 - OPEN THE ADAPTER SLEEVE BY INSERTING A SCREWDRIVER OR OTHER SUITABLE TOOL IN THE SLIT (DO NOT SCRATCH THE JOURNAL) AND SLIDE THE SLEEVE ALONG THE ROLL JOURNAL TO THE COLLAR.
 - GENTLY DRIVE THE BEARING INTO THE BEARING HOUSING UNTIL THE BEARING BOTTOMS IN THE HOUSING BORE. GENTLY STRIKE AROUND THE BEARING OUTER RACE EQUALLY WITH A RUBBER Mallet.
 - THE NARROW END OF THE BEARING BORE TAPER IS TO BE THE OUTSIDE OF THE HOUSING.
 - POSITION THE ROLL ON SADDLE BLOCKS AND SLIDE THE DUST SEALS OVER THE ROLL JOURNALS, ON TO THE ROLL COLLARS.
 - GENTLY DRIVE THE INNER OIL SEAL INTO THE BEARING HOUSING BY TAPPING EQUALLY AROUND THE SEAL WITH A RUBBER Mallet UNTIL FLUSH WITH THE HOUSING.
 - SLIDE THE BEARING HOUSING OVER THE ROLL JOURNAL AND INTO THE ADAPTER SLEEVE. LOCATE THE HOUSING MOUNTING HOLES 3.06 (77.72) FROM THE ROLL FACE.
 - SCREW ON THE BEARING LOCK NUT WITH ITS CHAMFER FACING THE BEARING, BUT DO NOT MOUNT THE LOCKING WASHER.
 - REMOVE THE SADDLE BLOCKS FROM THE ASSEMBLY END OF THE ROLL SO THAT THE BASE OF THE BEARING HOUSING IS SETTING ON THE FLOOR.
 - MEASURE THE BEARING RESIDUAL CLEARANCE USING FEELER GAUGES BETWEEN THE OUTER RING AND THE UPPER MOST (UNLOADED ROLLER). BEFORE MEASURING, THE BEARING SHOULD BE ROTATED A FEW TIMES TO ENSURE THAT THE ROLLERS HAVE ASSUMED THEIR CORRECT POSITION. DURING MEASUREMENT, THE ROLLER AT THE MEASURING POINT SHOULD BE LIGHTLY PRESSED AGAINST THE GUIDE RING BETWEEN THE TWO ROLLERS ROWS AND THE FEELER GAUGE BLADE BE INSERTED TO THE MIDDLE OF THE ROLLER. TIGHTEN THE LOCK NUT WITH A SPANNER WRENCH UNTIL THE CORRECT RESIDUAL RADIAL CLEARANCE IS REACHED. THE RESIDUAL CLEARANCE SHOULD BE A MINIMUM OF .0022 (.0559) AND A MAXIMUM OF .0032 (.0813).
 - UNSCREW THE LOCK NUT. THE BEARING WILL NOT COME LOOSE.
 - PLACE THE BEARING LOCK WASHER IN POSITION. TIGHTEN THE LOCK NUT FIRMLY, BUT MAKE SURE THAT THE BEARING IS NOT DRIVEN ANY FURTHER UP THE SLEEVE.
 - LOCK THE NUT BY BENDING ONE OF THE LOCKING WASHER TABS DOWN INTO ONE OF THE SLOTS IN THE NUT. DO NOT BEND THE TAB TO THE BOTTOM OF THE SLOT.
 - CHECK THAT THE ROLL JOURNAL ROTATES WITHOUT ANY DISTURBANCES.
 - PLACE SPACER RING INSIDE BEARING HOUSING, AGAINST BEARING OUTER RACE.
 - GENTLY DRIVE THE OUTER OIL SEAL INTO THE BEARING COVER BY TAPPING EQUALLY AROUND THE SEAL WITH A RUBBER Mallet UNTIL FLUSH WITH THE COVER.
 - SLIDE THE COVER OVER THE ROLL JOURNAL AND FASTEN TO THE BEARING HOUSING.
 - FILL BEARING HOUSING WITH GREASE, SEE NOTES.
 - REPEAT PROCEDURE FOR OPPOSITE BEARING HOUSING.
- DISMOUNTING PROCEDURE:
 - REMOVE THE BEARING HOUSING COVER.
 - DISENGAGE THE TAB OF THE LOCK WASHER FROM THE LOCK NUT.
 - LOOSEN (TURN COUNTERCLOCKWISE) THE LOCK NUT WITH A SPANNER WRENCH OR SOFT STEEL BAR AND HAMMER. LOOSEN NUT A FEW TURNS, BUT LEAVE ON SLEEVE.
 - USE A PIECE OF 5.00 ID (127.00) MINIMUM THICK WALL TUBING OR PIPE, LONG ENOUGH TO REACH THE ADAPTER OVER THE DRIVE JOURNAL WITH A PLATE WELDED OVER ONE END TO LOOSEN THE ADAPTER.
 - PLACE THE PIPE AGAINST THE END OF THE BEARING ADAPTER AND STRIKE THE PIPE SQUARELY, DRIVING THE ADAPTER INSIDE OF THE JOURNAL COLLAR.
 - THE BEARING HOUSING, BEARING AND ADAPTER WILL SLIP EASILY OFF THE ROLL JOURNAL.

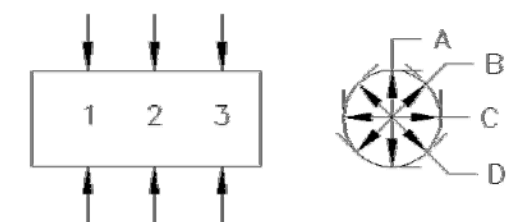

MEASUREMENT FORM

- NOTES:
- DO NOT SCALE FROM DRAWING;
 - ONE PIECE REQUIRED PER K000-00184: ROLLER MILL ASSY, 18 X 36".
 - FILL BEARING HOUSING WITH NLGI No. 2 GRADE LITHIUM GREASE WITH AT LEAST 1000 SSU @ 100° F UNTIL GREASE RELIEFS OPEN. APPROXIMATELY 56 FL OZ (4, 14 OZ TUBES), AFTER ASSEMBLY COMPLETE.

15	K914-07201	2	SEAL, NATIONAL 415294
14	K914-06701	2	SEAL, NATIONAL 417539
13	K910-06221	2	FITTING, RELIEF-ALEMITE 317-400 1/8-27 NPT
12	K902-14201	2	BEARING, 22228 CC/W33
11	K902-12801	2	WASHER, LOCK W-28
10	K902-11001	2	ADAPTER, BRNG-SKF SNW28X4.937"
9	K902-01401	2	NUT, LOCK AN-28
8	K201-00260	2	SEAL, DUST 4.938" JOURNAL 18/20"
7	K200-00540	1	ASSY, ROLL DRIVE FIN 4.94" DUAL DRIVE 18 X 36
6	K200-00144	1	RING, SPACER, BEARING XHD 228
5	K200-00069	2	COVER, OUTER PIVOT, BRNG HSG 228
4	K100-00524	2	BEARING HOUSING ASSY, PIVOT 228
3	70012050	2	CPLG, ELBOW 90 1/8-27M NPT X 1/4" TBG
2	66444400	12	WASHER, LOCK 3/8"
1	62584426	12	HHCS, 3/8-16 X 1.25"

ITEM	PART NUMBER	QTY	DESCRIPTION
<div style="display: flex; justify-content: space-between;"> <div> <p>Ferrell-Ross MATERIALS PROCESSING & RECOVERY SINCE 1967</p> </div> <div> <p>DIVISION OF A.T.FERRELL COMPANY 1440 S ADAMS ST BLUFFTON, INDIANA 46714 - USA PH: 260-824-3400 FAX: 260-824-5463</p> </div> <div> <p>This drawing is the property of the A.T. Ferrell Company, Inc and must be returned immediately upon request. No part of this drawing may be reproduced, stored in a retrieval system or transmitted in any form or by any means, without prior written consent of the A.T. Ferrell Company, Inc.</p> </div> </div>			
<p>TOLERANCES EXCEPT AS NOTED</p>			<p>TITLE: ROLL & BEARING HOUSING ASSY, PIVOT, DUAL DRIVE 18 X 36"</p>
<p>DECIMAL: XX ± .030 XXX ± .005 XXXX ± .001</p>	<p>FRACTIONAL: ± 1/32</p>	<p>FINISH: NONE</p>	<p>DRAWN BY: pggalea</p>
<p>SCALE: 1:4</p>		<p>SHEET: 2 OF 2</p>	<p>APPROVED BY: DMJ</p>
<p>CAD NO MANUAL CHANGES</p>			<p>SIZE: D PART NUMBER: K100-03050 REV: B</p>